

---

# BIOLOGICAL MICROSCOPE

# Magnüs

## INSTRUCTIONS

This instruction manual is for the Magnus Biological Microscope Model MLX to ensure the safety, obtain optimum performance, and familiarize yourself fully with the use of this microscope, we recommend you study this manual thoroughly before operating the microscope. Retain this instruction manual in an easily accessible place near the work desk for future reference.

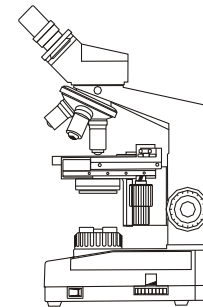

## IMPORTANT

Be sure to read and observe the caution and notes in this section. Otherwise injury or damage to the instrument may result.

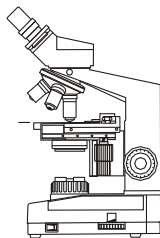

## SAFETY PRECAUTIONS

(Figs. 1 & 2)

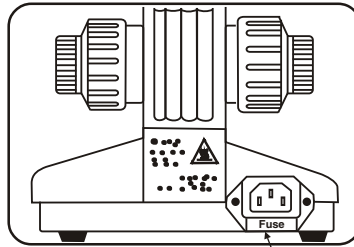

Fig. 1

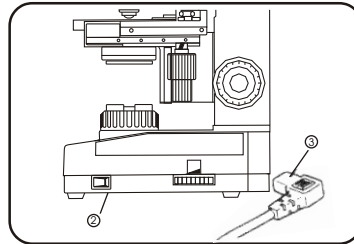

Fig. 2

1. Before replacing the lamp bulb, be sure to set the main switch ② to (OFF), unplug the power cord from the power outlet and wait until the lamp and its surroundings have cooled down fully. (Fig.2)
2. Before replacing fuse ① F<sub>1</sub> 250V/750mA be sure the main switch remain OFF & unplug the power cord ③ from the power outlet. Open the fuse socket from power outlet by means of sharp edge pen or pencil from the top and replace the fuse.

Applicable lamp bulb

6V20W/HAL

**IMPORTANT**

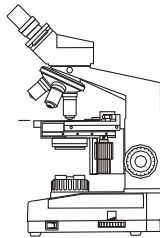
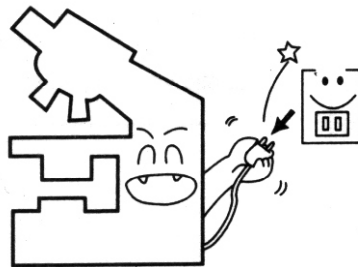
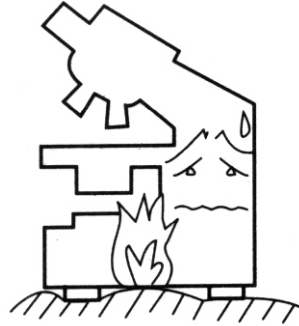







3. Place the microscope on a flat, level surface which does not block the ventilation opening on the bottom. Do not place the microscope on a soft surface into which it may sink, for this will block the ventilation opening on the bottom and may lead to a fire hazard. Also, do not place the microscope near an object which may impede switching of the main switch on and off.
4. Be sure to use the power cord provided with the microscope. We cannot warrant the safety and performance of the microscope unless the provided power cord is used.
5. Be sure to earth the microscope to avoid damage in an emergency.
6. Never insert a thin object like a wire into the ventilation opening on the bottom. Otherwise an electric shock or malfunction will result.
7. Before placing the dust cover on the microscope, wait until the lamp and its surroundings have cooled down fully, and unplug the power cord from the power outlet.

**IMPORTANT**

**Safety Symbols**

The following symbols are found on the microscope. Study the meaning of the symbols, and always use the equipment in the safest possible manner.

Symbol	Explanation
	Indicates that the surface becomes hot, and should not be touched with bare hands.
	Before use, carefully read the instruction manual. Improper use could result in personal injury to the user and/or damage to the equipment.
	Indicates that the main Electrical Hazard.
	Indicates that the main switch is ON.
	Indicates that the light intensity control from Min to Max.
	Indicates that the Fuse F, 250V/750mA is in power socket.

**Warning Label**

A warning indication label is attached to every part which should be handled or operated with special care. Be sure to observe the indications.

Warning indication position	Bottom of the base (Warning against high temperature) 
-----------------------------	---------------------------------------------------------------------------------------------------------------------------------------------

If the warning label is stained or peeled off, please contact your local Magnus representative for replacement or other inquiry.

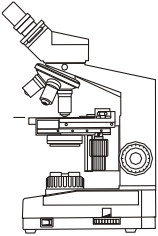

**IMPORTANT**

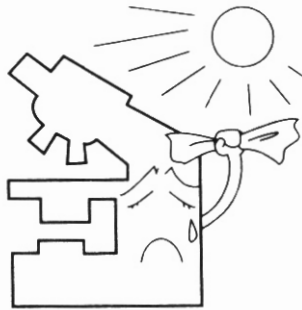

No high temperature or humidity!

## 1 When using the Microscope

1. A microscope is a precision instrument. Handle it carefully, taking care not to hit it against an object. Do not disassemble the microscope or drop its lens on the floor, for this makes accurate observation impossible.
2. Avoid using the microscope in places where there is direct sunlight, high temperature, high humidity, dust or vibration.  
(For the operating environment condition, see "SPECIFICATIONS" on page 17.)
3. Be sure to use the tension adjustment ring when adjusting the tension of the coarse focus adjustment knob (see page 16).

## 2 Maintenance and Storage

1. Clean all glass components by wiping gently with gauze. To remove fingerprints or oil smudges, wipe with gauze slightly moistened with a mixture of ether (70%) and alcohol (30%)

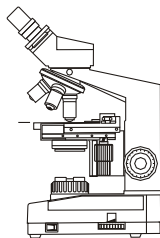

**IMPORTANT**

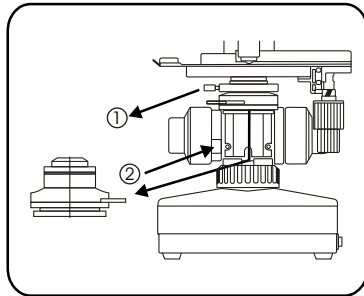
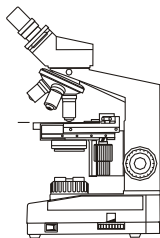

Fig.3

**⚠ Since solvents such as ether, alcohol are highly flammable, they must be handled carefully. Be sure to keep these chemicals away from open flames or potential sources of electrical sparks - for example, electrical equipment that is being switched on or off. Also remember to always use these chemicals only in a well-ventilated room.**

2. When cleaning parts other than the lenses, do not use the above chemicals. If they are seriously dirty, wipe with gauze moistened slightly with a solution of neutral detergent.
3. Never attempt to remove parts other than those specified from the microscope for cleaning.
4. When the microscope is not used, ensure that the light source lamp is cool, cover the microscope with a dust cover or put it in a wood case, and store in a dry place.
5. To clean the condenser, fully loosen the securing knob ①, then remove the condenser by lowering it with the condenser up-down movement knob ②, and clean the upper lens of the condenser.  
The lens can be cleaned using the same method as described in Fig.3. Wipe it as lightly as possible. Reverse the removal procedure to attach the condenser.

**IMPORTANT**

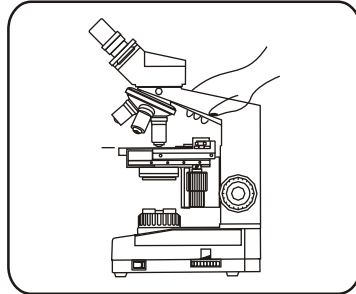

Fig. 4

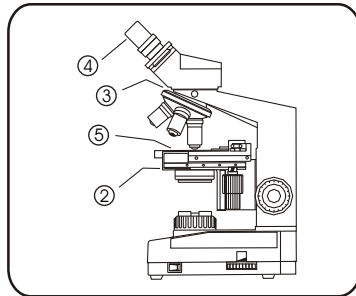
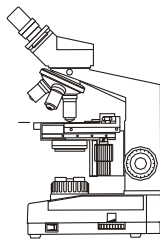

Fig. 5



**3 When Carrying the Microscope (Figs.4 & 5)**

To carry the microscope, hold around the arm with hand as shown in Fig. 4 and carry carefully.

**⚠ Do not hold the microscope by the stage ②, or observation tube ③. Also be careful not to drop the eyepiece ④ and specimen ⑤.(Fig.5)**

**4 Caution**

If the microscope is used in a way not specified by this manual, the safety of the user may be imperiled, and the equipment may be damaged. Always operate the microscope as outlined in this instruction manual.

The warning, caution and other notes in this manual use the following symbols.

**⚠** : Warning to prevent injury to the user or damage to the product.

**CAUTION** : Caution for preventing damage to the product.

**Ⓞ** : Reference note or remark (convenient information for operation and/or maintenance)

**CONTENTS**

**COMPONENT UNITS 1**

**FUNCTION OF EACH PART 2**

**ASSEMBLY 3**

**OBSERVATION FLOW 9**

**OPERATION PROCEDURE 10**

**SPECIFICATIONS 17**

**TROUBLESHOOTING GUIDE 20**

**1** Turning the Lamp ON..... 10

**2** Placing Specimen on the Stage..... 10

**3** Focusing..... 12

**4** Adjusting the Interpupillar Distance. 13

**5** Adjusting the Diopter..... 14

**6** Adjusting the Condenser Position  
and Iris Diaphragm..... 14

**7** Varying the Magnification..... 15

**8** Adjusting the Tension of the Coarse  
Focus Adjustment Knob..... 16

**9** Locking of the prefocusing lever..... 16

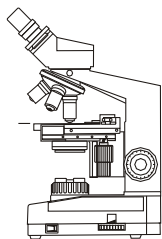

## COMPONENT UNITS

These units constitute your microscope

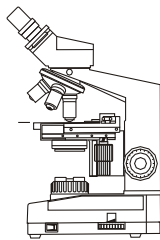

### Eyepiece lenses

Observe specimens by looking through the eyepiece lenses which magnify the image formed by an objective.

### Revolving nosepiece\*

Objectives are mounted on this part. Rotating this part easily changes magnification.

### Stage\*

The specimen is placed here.

### Condenser

This incorporates lenses which collect illumination light on the stage so that the objectives can perform at full capability.

### Pre-focusing lever

\* These parts are fixed and should not be removed from the microscope frame.

### Observation tube

(A monocular tube, trinocular tube or binocular tube is provided, depending on the composition of your microscope.)

### Mechanical stage\*

Mechanical stage is provided,

### Objective

This lens is used to magnify a specimen image. The higher the magnification number of an objective, the greater the detail seen in specimen parts.

### Microscope frame

**FUNCTION  
OF  
EACH PART**

© The description on this page uses the binocular tube composition using the MLX-B, as an example.

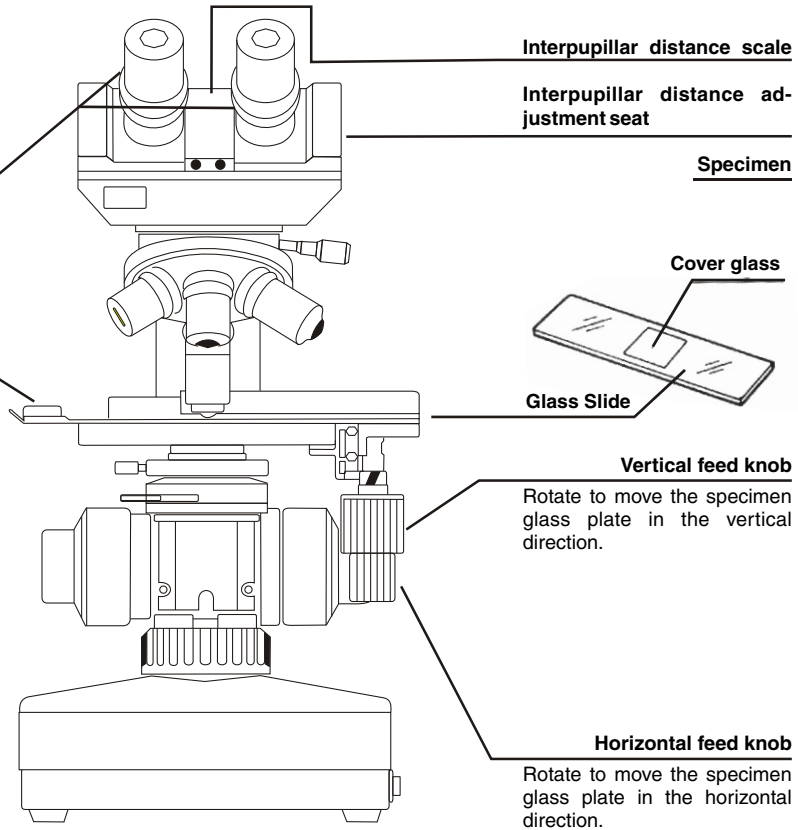

**Diopter adjustment ring**

Rotate to compensate for observer's eyesight.

**Specimen holder**

The specimen glass plate is fixed here.

**Interpupillar distance scale**

**Interpupillar distance adjustment seat**

**Specimen**

**Cover glass**

**Glass Slide**

**Vertical feed knob**

Rotate to move the specimen glass plate in the vertical direction.

**Horizontal feed knob**

Rotate to move the specimen glass plate in the horizontal direction.

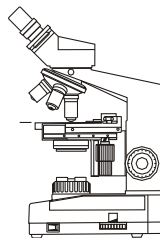

# ASSEMBLY

To ensure accurate observation be careful not to drop the objective or eyepiece. Be very cautious in assembly.

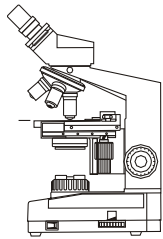

## Overall Assembly Diagram

Ⓢ Refer to following pages for the detailed assembly diagram of each unit. The following figure shows the outline of assembly and the order of assembly steps.

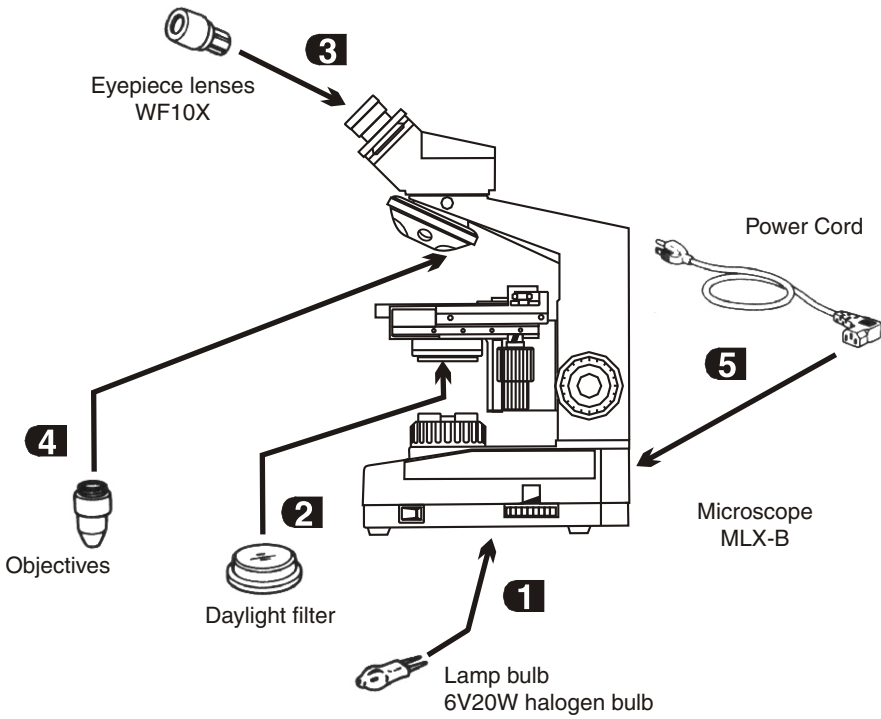

# ASSEMBLY

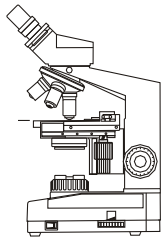

## Detailed Assembly Procedures

### 1 Attaching (Replacing) the Lamp Bulb (Figs.6-8)

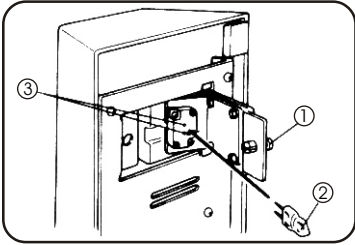

Fig. 6

1. Place the microscope on the back so that the bottom of the base can be seen from the front, then open the lamp bulb replacement cover by pulling the lock knob ① (Fig.6)
2. Hold the lamp bulb ② without taking it out of the polyethylene bag so as not to stain the bulb with fingerprints, etc., and push the bulb into the pin holes in the socket ③, paying attention not to leave your fingerprints on the bulb. (Fig.6)  
After attaching the bulb, move the polyethylene bag from it.

Applicable lamp bulb	6V20WHAL
----------------------	----------

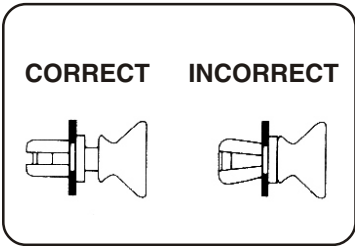

Fig. 7

- CAUTION** Be sure to use the specified lamp bulb. Using a bulb other than a specified one may lead to a fire hazard.
- ⚠** Fingerprints or stains on the lamp bulb reduce its service life. When it is contaminated, wipe with gauze slightly moistened with alcohol or a similar chemical.
- 3. With the lock knob left in the pulled-out position, close the lamp bulb replacement cover. Then push in the lock knob to lock the cover. (Fig.7)  
**CAUTION** The cover cannot be closed if the lock knob is in the pushed-in position. Make sure that it is in the out position before closing the cover.

**ASSEMBLY**

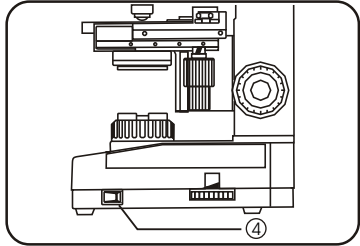

Fig. 8

**Caution for Lamp Bulb Replacement**

**▲** Before replacing the bulb, set the main switch ④ to (OFF), unplug the power cord and wait until the bulb and its surroundings have fully cooled down to prevent electric shock or burns. (Fig. 8)

**CAUTION** If the lamp bulb burns out during observation and needs replacement, remove the parts that may drop (such as the eyepiece lenses and specimen) from the microscope, then place the microscope on its back.

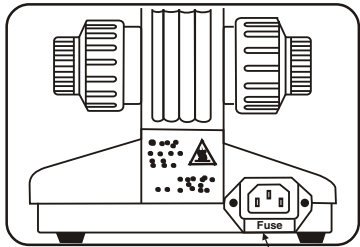
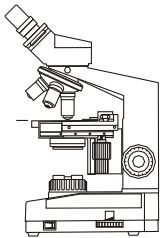

Fig. 9

**2 Replacement of fuse (Fig. 9)**

**CAUTION** Disconnect the power cord before replacement of the fuse ①



# ASSEMBLY

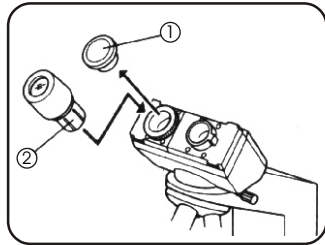
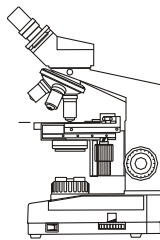

Fig. 10

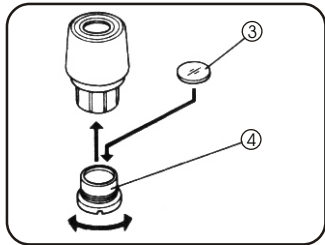

Fig. 11

## 3 Attaching the Eyepiece Lenses (Figs.10 & 11)

1. Remove the eyepiece cap ①. (Fig.10)
2. Insert the eyepiece lens ② into the observation tube. (Fig.10)
3. When the observation tube is binocular, attach the other eyepiece lens in the same way as above.

**CAUTION** Do not tilt the microscope while eyepiece lenses are attached. Otherwise the eyepiece lenses may drop.

**CAUTION** Do not insert anything other than eyepiece lenses into the observation tube for it contains optical components.

### Attaching the Eyepiece Micrometer\* (Special Accessory) (Fig.11)

The WF10X eyepiece can incorporate micrometer scales. A variety of eyepiece micrometers are available according to the desired observation methods.

1. Remove the holder ring ③ at the bottom of the eyepiece lens by pulling out.
2. Hold the eyepiece micrometer ④ with the scale side down and place it on the holder ring ③.
3. Push in the holder ring ③ into the eyepiece lens and attach the combination to the observation tube.

★ The eyepiece micrometer should have a diameter of 19 mm.

# ASSEMBLY

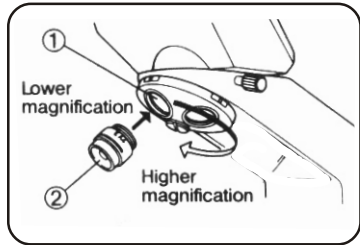

Fig. 12

## 4 Attaching the Objectives (Fig. 12)

Attach each objective ② to each lens mount hole ① of the revolving nosepiece, starting from the lowest-magnification objective and increasing the magnification in the clockwise direction seen from the bottom.

- ◎ By attaching objectives in this way, the objectives can be switched in ascending order of magnification.

## 4 Attaching the Power Cord (Figs. 13 & 14)

- ▲ Do not damage, destroy, process, excessively bend, pull, twist, bundle, place a heavy object on or pinch a power cord. Otherwise the cord may become worn, causing an electrical shock or fire hazard.
- ▲ Always use the power cord provided with the microscope.

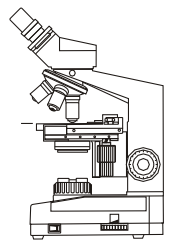

**ASSEMBLY**

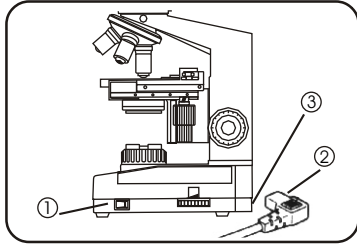

Fig. 13

To prevent an electric shock, set the main switch ① to (OFF) before plugging the power cord. (Fig. 13)

1. Insert the connector ② of the power cord into the connector ③ securely. (Fig. 13)

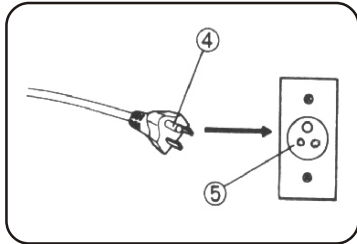
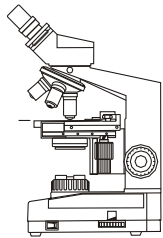

Fig. 14

2. Plug the power cord plug ④ into a wall outlet ⑤. (Fig. 14)  
▲ Connect the power cord correctly and make sure that the earth terminal of the power supply and that of the wall outlet are properly connected. If the equipment is not earthed, Magnus can no longer warrant the electrical safety and performance of the equipment.



## OBSERVATION FLOW

Once you have understood the detailed operation procedure on the following pages, you will be able to operate the microscope simply by referring to the chart on this page.

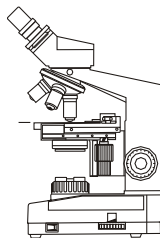

Turning the Lamp ON

Page 10



Placing Specimen on the Stage

Page 10



Engaging the 10X Objective in the Light Path

Page 12



Focusing

Page 12



Adjusting the Condenser Position

Page 14



With a binocular tube :

Adjusting the Interpupillar  
Distance

Page 13



With a binocular tube :

Adjusting the Diopter

Page 14



Observation (Engaging the desired objective in the light path, adjusting the brightness and focusing)

# OPERATION PROCEDURE

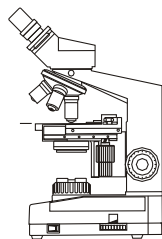

1

## Turning the Lamp ON

(Fig. 15)

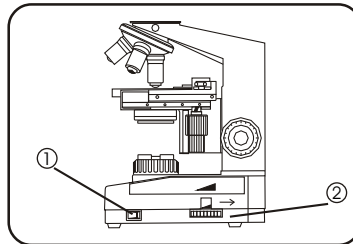

Fig. 15

▲ Repeated ON and OFF of the main switch may cause malfunction.

1. Set the main switch ① to "O" (ON).
2. Adjust the brightness by rotating the brightness adjustment knob ②.

Rotating the knob in the direction of the arrow increases brightness and rotating it in the opposite direction decreases brightness. (↶)

2

## Placing Specimen on the Stage

(Figs. 16 & 17)

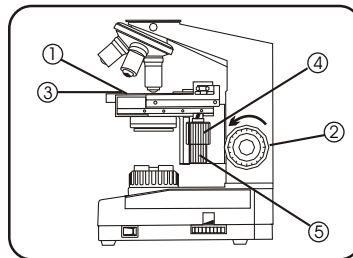

Fig. 16

**CAUTION** Set the specimen's glass plate carefully. Be careful not to damage the glass slide edges by returning the bow-shaped lever ① violently or releasing the bow-shaped lever knob in the middle of operation.

1. Fully lower the stage by rotating the coarse focus adjustment knob ② in the direction of the arrow.
2. Open the bow-shaped lever ① outward, place the specimen glass plate ③, gently return and fix the bow-shaped lever to the original position.

## OPERATION PROCEDURE

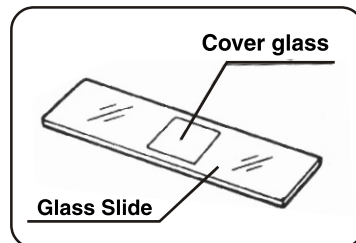

Fig. 17

- Rotating the upper knob which is the vertical feed knob ④ moves the specimen glass plate in the front-rear direction; rotating the lower knob which is the horizontal feed knob ⑤ moves it in the lateral direction. While watching the specimen move the specimen, to the desired position.

### Glass Slide (Fig. 17)

This should be a transparent, colorless glass plate with a length of 76 mm, width of 26 mm and thickness between 0.8 and 1.4 mm.

The recommended thickness is between 0.9 and 1.2 mm.

### Cover glass (Fig. 17)

This is the glass plate placed on the specimen and should have a thickness of 0.17 mm. Dimensions of 18 x 18 mm or 18 x 24 mm are most suitable for ease of observation.

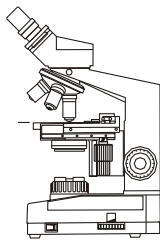

## OPERATION PROCEDURE

### 3 Focusing

(Fig. 18)

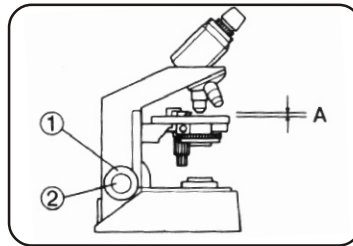
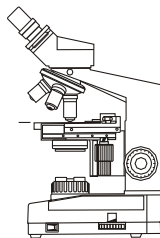

Fig. 18

1. Rotate the revolving nosepiece so that the 10X objective comes above the specimen.
- ★ Here, we use the 10X objective because it makes focusing easiest.
2. While looking at the microscope from the side, rotate the coarse focus adjustment knob ① to approach the specimen until it is as close as possible to the objective.
3. While observing the specimen through the eyepiece lenses, lower the stage by slowly rotating the coarse focus adjustment knob ① and, when coarse focusing is obtained, adjust to precise focus by rotating the fine focus adjustment knob ②.

**CAUTION** The following table shows the distance between the objective and specimen (“A” in Fig. 18) when precise focus is obtained.

Objective Magnification	4x	10x	40x
Distance A	29.0 mm	6.30 Mm	0.53 mm



## OPERATION PROCEDURE

4

### Adjusting the Interpupillar Distance (With a binocular microscope)

(Fig. 19)

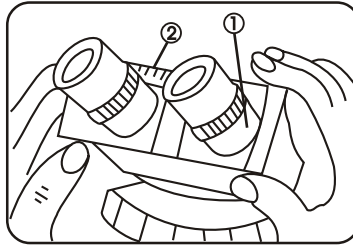
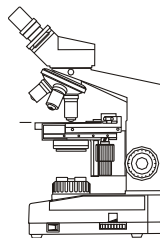

Fig. 19

- ◎ The interpupillar distance adjustment consists of regulating the distance between your eyes so that they can observe a single microscopic image. This greatly helps to reduce fatigue during observation.
1. While looking through the eyepiece lenses, adjust the interpupillar distance by sliding the interpupillar distance adjustment seat ① left and right. (Fig. 19)  
The interpupillar distance adjustment seat ① is provided with an interpupillar distance scale ②. By memorizing your interpupillar distance according to the scale, you can adjust the interpupillar distance easily next time. (Fig. 19)



## OPERATION PROCEDURE

### 5 Adjusting the Diopter (With a binocular microscope) (Fig. 20)

(Fig. 20)

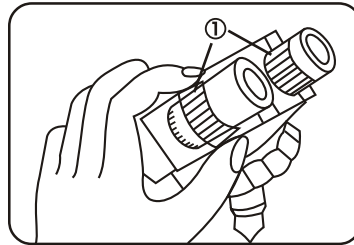

Fig. 20

The diopter adjustment consists of compensating for observer's left and right eye vision.

1. Look into the right eyepiece lens with your right eye and focus the specimen by rotating the coarse focus adjustment knob and/or fine focus adjustment knob.
2. Look into the left eyepiece lens with your left eye and rotate the diopter adjustment ring ① alone to focus on the specimen.

Now vision for both eyes has been compensated for.

Note:- The left & right diopter adjustment +5 to -5

### 6 Adjusting the Condenser Position and Iris Diaphragm (Fig. 21 & 22)

(Fig. 21 & 22)

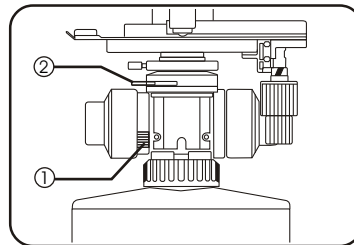
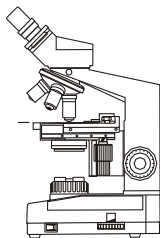

Fig. 21

- ⊙ The condenser is usually used in the highest position. If the entire observed field of view is not bright enough, brightness may be improved by lowering the condenser slightly.
1. Move the condenser to the highest position by rotating the condenser up-down movement knob ① . (Fig. 21)



## OPERATION PROCEDURE

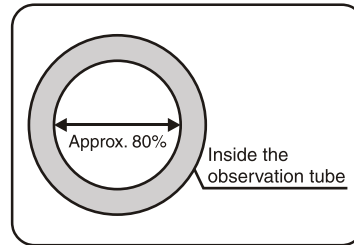

Fig. 22

2. Remove the eyepiece lenses from the observation tube, look into it and rotate the condenser iris diaphragm Lever ②.

A good image may be obtained by adjusting the iris diaphragm to about 80% as shown in Fig. 22. This adjustment is required every time after the objective is changed.

### 7

#### Varying the Magnification

1. Hold the revolving nosepiece and rotate it until the desired objective comes above the specimen.

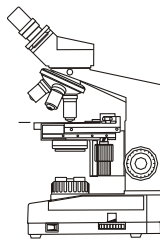

## OPERATION PROCEDURE

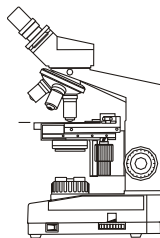

### 8 Adjusting the Tension of the Coarse Focus Adjustment Knob (Fig. 23)

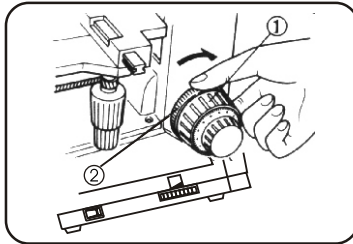

Fig. 23

- ⊙ For ease of control, the rotation tension of the coarse focus adjustment knob is adjustable.
1. While holding the coarse focus adjustment knob ①, rotate the coarse focus adjustment knob tension adjustment ring ②. Rotating the adjustment ring in the direction of the arrow increases the tension of rotation, and rotating the ring in the opposite direction decreases the tension.
  2. If the stage lowers itself due to its weight or focussing position obtained with the fine focus adjustment knob is lost easily, the tension of the coarse focus adjustment knob may be too loose. Increase the tension by rotating the adjustment ring ② in the direction of the arrow. (Fig.23)

### 9 Locking of the prefocusing lever (Fig. 24)

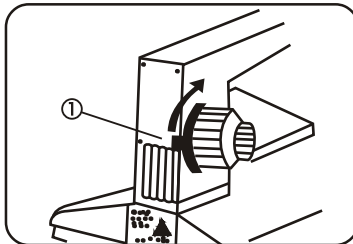
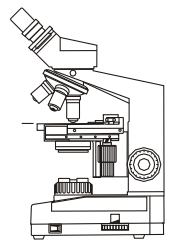

Fig. 24

This lever ① is provided to prevent possible contact between specimen and objective as well as to simplify coarse focusing. The lever is locked in the clockwise direction after coarse focus has been accomplished. It prevents further upward travel of the stage by means of the coarse adjustment knobs & provide a limiting stop if the stage is lowered and then raised again. The prefocusing lever does not restrict fine focusing. (Fig.24)

**STANDARD  
SPECIFICATIONS**

Item		Specification
1. Illumination system		6V20W halogen bulb.
		Power Supply = 220/230-240 V ~ 0.2 A 50 Hz
2. Focusing mechanism		Coaxial coarse/fine focus adjustment knobs based on up-down stage movement. Coarse/fine knob stroke: 22 mm Coarse knob tension adjustable. Fine knob scale: 2.0 $\mu$ m scale. Fine knob: 0.2 mm per turn
3. Revolving nosepiece		4-hole revolving nosepiece with fixed arm. Front oriented.
4. Observation tube	Monocular	Tube inclination angle 45°
	Binocular	Tube inclination angle 45° Interpupillar distance adjustment range: 55 to 75 mm. Left & right diopter adjustment: $\pm$ 5 diopters.



**STANDARD SPECIFICATIONS**

Item		Specification
5. Stage	Type	With mechanical stage
	Size	125 (W) x 145 (L)
	Movement range	76 (H) x 50 (V)
	Scale	Vertical-horizontal feed scale/indicators V scale: 0-50 mm H scale: 100-170 mm Minimum readout: 0.1mm on main scale
	Specimen fixation	Specimen holder lever
6. Condenser	N.A.	1.25 (when immersed in oil)
	Aperture iris diaphragm	iris diameter 1.7 to 30 mm
	Up-down Stroke	20 mm (Detachable)
	Daylight Filter	Detachable

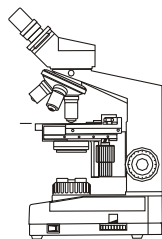

**STANDARD  
SPECIFICATIONS**

<b>Item</b>	<b>Specification</b>
7. Dimensions & weight (With a binocular observation tube and mechanical stage)	200 (L) x 258 (W) x 386 (H) mm. Approx. 6.28 kg

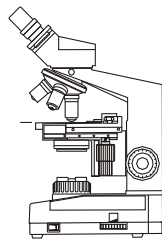

## TROUBLE-SHOOTING GUIDE

Under certain conditions, performance of the microscope may be adversely affected by factors other than defects. If a problem occurs, please review the following list and take remedial action as needed. If you cannot solve the problem after checking the entire list, please contact your area Magnus representative for assistance.

Problem	Cause	Remedy	Page
1. Uneven brightness in observation field.	Objective is not engaged in the light path.	Engage the objective into position until it clicks.	7
	The condenser is too low.	Move it to the upper limit.	14
	The objective, eyepiece, condenser and/or window lens are dirty.	Clean them thoroughly.	V
. Dust or stains are visible in observation field.	The eyepiece, condenser, window lens and/or specimen glasses are dirty.	Clean them thoroughly.	V

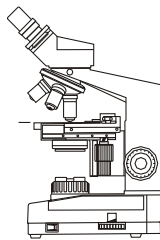

## TROUBLE-SHOOTING GUIDE

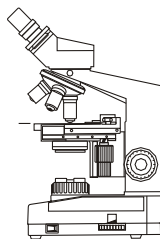

Problem	Cause	Remedy	Page
3. Glaring Observation image	The condenser is too low.	Move it up.	14
	The condenser iris diaphragm dial is set too narrow.	Increase the aperture to about 80%	14&15
4. The observed image is whitish-blurred or unclear.	Objective is not engaged in the light path.	Engage the objective in position until it clicks.	7
	The objective, eyepiece, condenser and/or specimen glass is dirty.	Clean them thoroughly.	V
	Immersion oil is not used with immersed objective.	Use immersion oil	24
	Bubble is mixed in the immersion oil.	Remove the bubble.	25
	The specified immersion oil is not used.	Use the specified immersion oil.	24
5. Part of image is defocused or image looks like it's flowing.	Objective is not engaged properly in the light path.	Engage the objective in position until it clicks.	7
	The specimen is not set properly on the stage.	Set the specimen correctly on the stage and fix securely using the specimen holder.	10&11

## TROUBLE-SHOOTING GUIDE

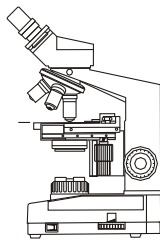

Problem	Cause	Remedy	Page
6. High-magnification objective touches specimen just before coming into focus.	Specimen is upside down.	Set the specimen correctly with the cover glass on the top.	10&11
7. The tension of coarse focus adjustment knob is too high.	Coarse focus adjustment Knob tension adjustment ring is set too tight.	Loosen the ring to adjust to proper tension	16
8. Stage lowers due to its weight or focusing is lost due to slippage of coarse focus adjustment knob.	Coarse focus adjustment Knob tension adjustment ring is set too loose.	Tighten the ring to achieve proper tension.	16
9. Coarse focus adjustment knob cannot move the stage low enough.	The condenser is too low.	Move it up.	14
10. The fields of view of two eyes do not match (when a binocular tube is used)	The interpupillar distance is not adjusted properly.	Adjust it properly.	13
	Vision is not compensated for both eyes.	Adjust correctly.	14
	The left and right eyepiece lenses are different.	Replace a lens so that the left and right lenses are identical.	6

## TROUBLE- SHOOTING GUIDE

Problem	Cause	Remedy	Page
11. Objective hits the specimen when an objective is switched to a higher magnification objective.	The specimen is upside down.	Set the specimen correctly with the cover glass on the top.	10&11
	The cover glass is too thick.	Use cover glass with thickness of 0.17 mm.	11
12. Lamp bulb does not light.	Lamp bulb is not mounted.	Attach a bulb.	4
	Lamp bulb is blown.	Replace the bulb.	4
	Power cord is unplugged.	Plug it securely.	7 & 8
	The fuse is blown. F <sub>1</sub> 250V/750mA	Unplug the power cord and replace the fuse.	
13. Lamp bulb blows easily.	The specified bulb is not used.	Replace with a specified bulb.	4

<< Built-in fuse specification >> F<sub>2</sub> 250V/750mA & F<sub>3</sub> 250V4A to be replaced by removing Bottom electrical Base.

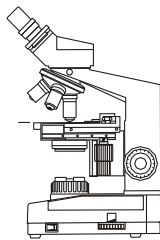

## Using an Immersion Oil Objective

(Fig. 25)

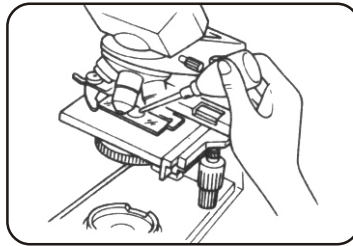
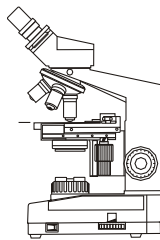
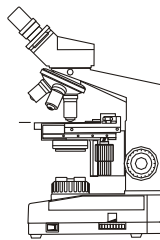

Fig. 25

- © An immersion oil objective cannot exhibit its performance unless immersion oil is applied to the tip of the objective.
1. Attach the objective (100X oil) to the revolving nosepiece (refer to “4 Attaching the Objectives” on page 7).
  2. Use a high-magnification objective other than the 100X objective and focus the specimen.
  3. Attach one or two drops of the specified immersion oil onto the specimen cover glass.





4. Engage the Magnus 100X Objective in the light path by rotating the revolving nosepiece and focusing the specimen with the fine focus adjustment knob.

**CAUTION** The image view is poor if bubbles are mixed into the oil, so be careful not to mix bubble in the oil.

- a) The presence of bubbles can be checked by removing the eyepiece lenses, fully opening the field iris diaphragm and condenser iris diaphragm and looking into the observation tube sleeve(s).
  - B) To remove the bubble, reciprocate the 100X objective a few times by rotating the revolving nosepiece.
  - ⓐ When the immersed objective is used, the condenser can exhibit full performance if oil is applied to both the bottom side of the specimen and the top surface of the condenser. Without oil, the observed image becomes slightly dark.
5. After use, remove the immersion oil on the objective lens tip by wiping with gauze slightly moistened with alcohol.

**CAUTION** Do not use too much alcohol or solvent for these chemicals may dissolve the lens adhesive agent.

---

# Magnüs

## Magnus Analytics

A-5 Mohan Coop. Industrial Area  
Mathura Road, New Delhi-110 044 (INDIA)  
E-mail: [magnus@touchtelindia.net](mailto:magnus@touchtelindia.net)

